

THE ILLINOIS STATE TOLL HIGHWAY AUTHORITY

February 13, 2020

DESIGN BULLETIN No. 20-02

SUBJECT: Noise Abatement Wall, Parapet, and Concrete Barrier Mounted Sign Supports

The following revisions and additions to the Illinois Tollway Standard Drawings Section F Sign Structures have been implemented facilitating accessibility during installation and maintenance.

Standard Drawing F11 has been revised and updated. In addition, four (4) additional standard drawings have been added to Section F as described below.

Noise Abatement Wall (NAW) Mounted Sign Support: The 2019 Structure Design Manual specifies a minimum NAW offset of 29" from the front face of NAW to the toe of barrier. The specified 29" offset creates insufficient space to install roadway signs between the roadway and NAW. The 2019 Roadway Signing and Pavement Marking Guidelines Section 2.15 has been updated to allow mounting signs to new NAWs provided that the NAW designs account for the signs and mounting heights. The mounting heights shall be a minimum of 14'-6" above the roadway level. Where the mounting is above the NAW height, the sign support bracket shall be mounted on the NAW posts.

Parapet Mounted Sign Support: At various bridge and retaining wall locations there is no space to mount required regulatory and warning signage without the sign overhanging the roadway. The sign mount detail utilized on previous Illinois Tollway projects had the mount attached to the back of the barrier which has been found to be undesirable due to accessibility issues for maintenance. The new design mitigates those accessibility concerns.

Milepost Marker: The existing milepost marker assembly had some premature failures in the welds. Sign Standard F11 has been revised to strengthen the connection of the post to the base utilizing T-fittings in addition to the welded joint.

Median Barrier Mounted Sign Support: There is currently no separate standard for the median barrier mounted signs. In the absence of the standard, Design Section Engineers (DSE) utilized the milepost marker support to install the sign panels which had a larger sign area than its capacity. A new standard has been developed utilizing telespar posts for the sign post for sign areas up to 20 SF.

The affected standards and new standard are per below:

Standard Drawings:

Revised Drawings: F11

New Drawings: F18, F19 and F20

DSEs are hereby directed to incorporate this design bulletin into all contracts currently under design, currently being advertised and all future contracts.



Paul D. Kovacs, P.E.
Chief Engineering Officer

02/24/2022
Date

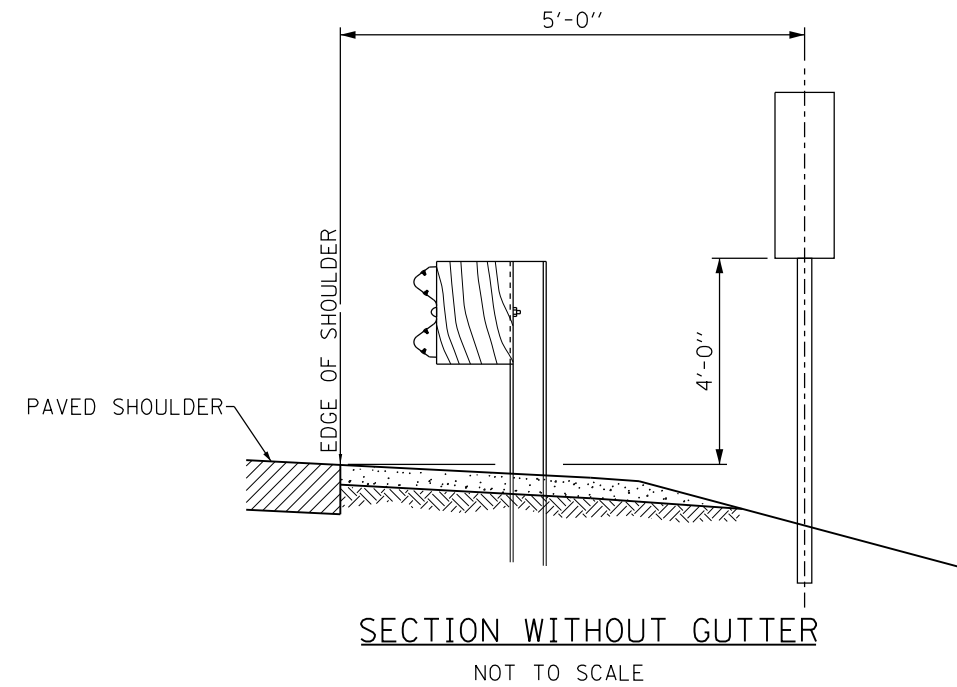
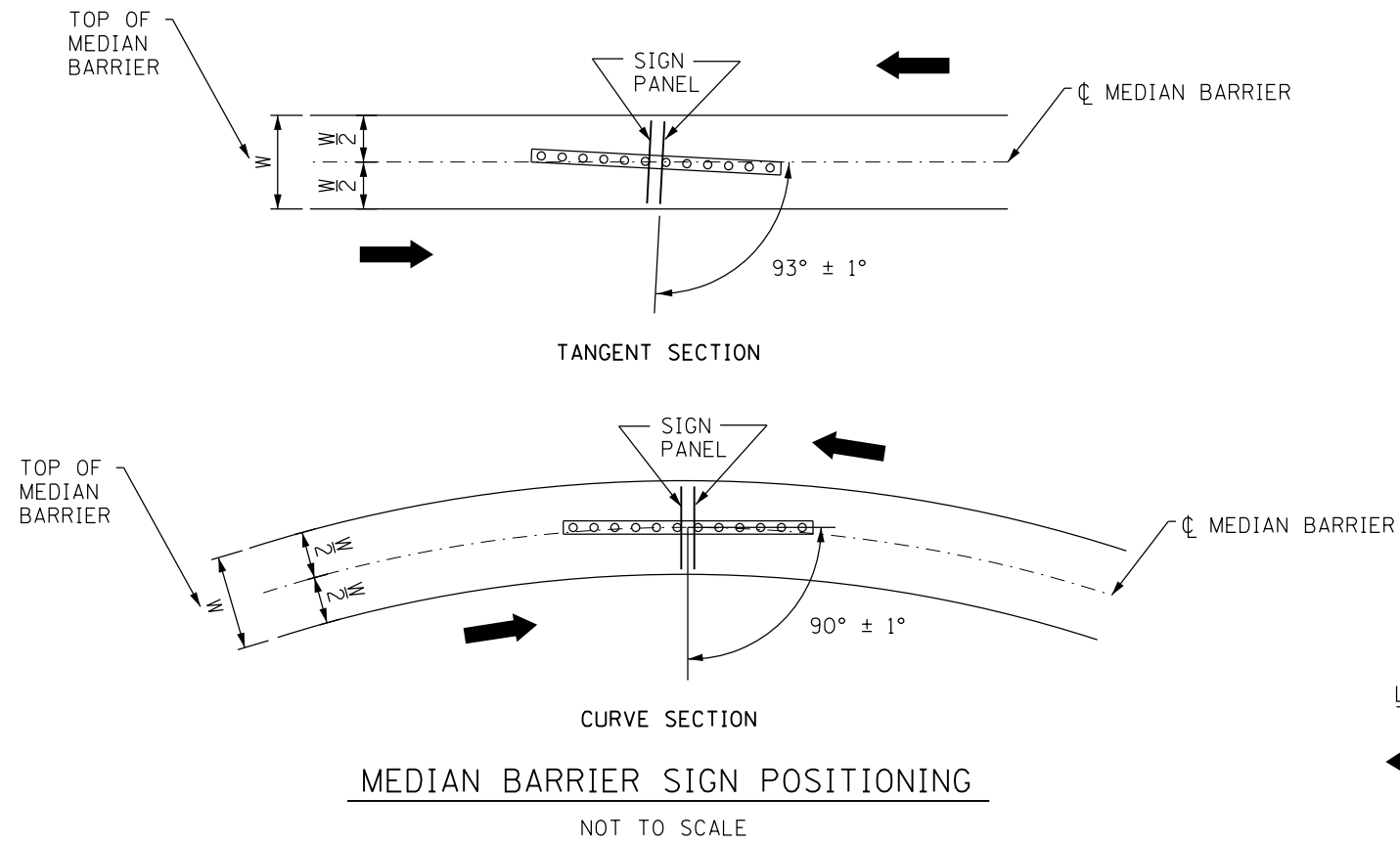
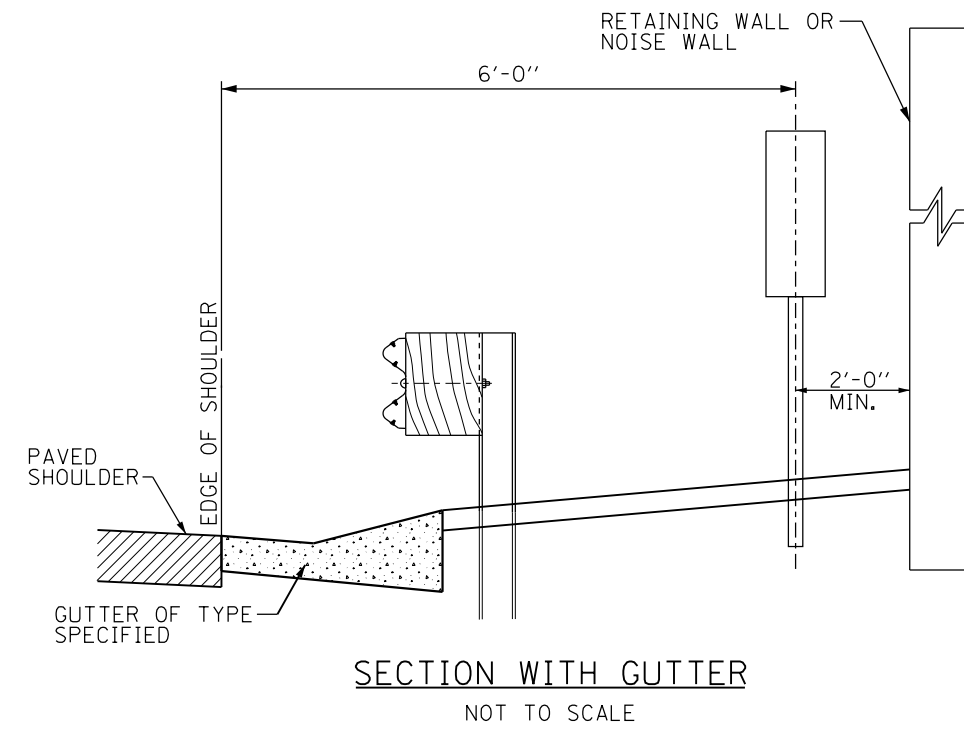
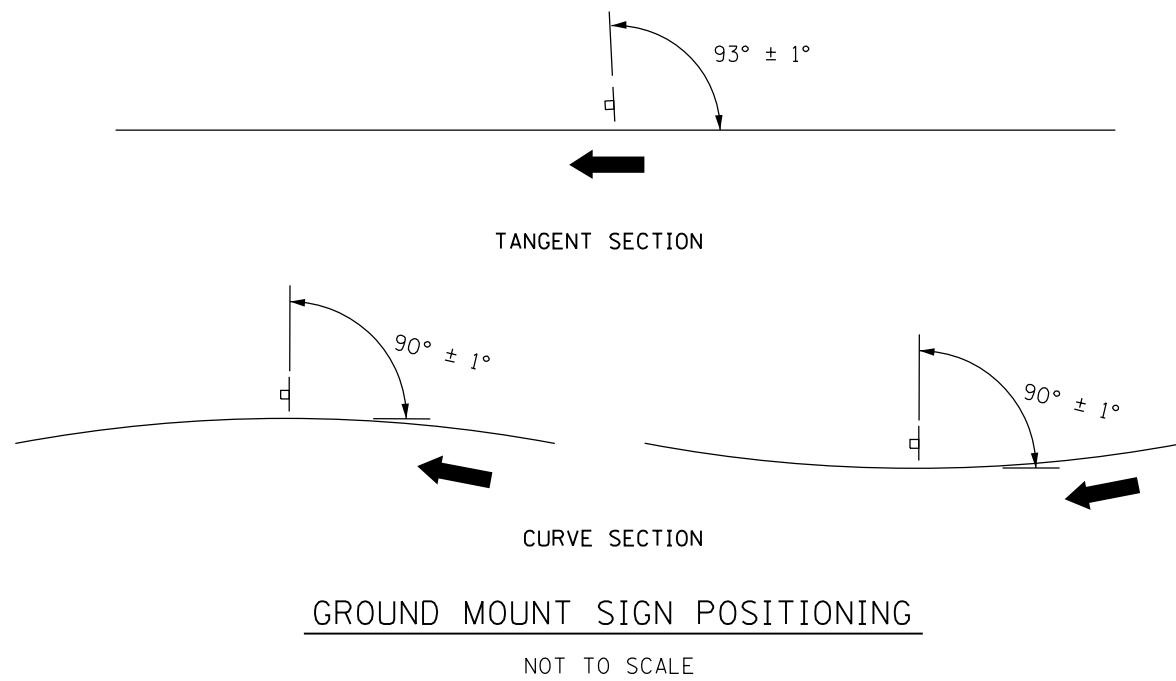

LEGEND:
 DIRECTION OF TRAFFIC

APPROVED: *Paul Kovacs* DATE 4-6-2009
CHIEF ENGINEER

| DATE | REVISIONS |
|-----------|---|
| 5-8-2009 | POSITIONING DETAILS |
| 8-1-2009 | REVISED BARRIER WALL MOUNT |
| 3-1-2013 | REMOVED MILE POST SIGNS |
| 3-31-2016 | REVISED BOLT NOTE |
| 3-01-2019 | REMOVED "LIGHT POLE/SIGN STRUCTURE MOUNT DETAIL" |
| 2-13-2020 | REVISED BARRIER MOUNT DETAIL AND GENERAL NOTES, ADDED MILEPOST HEIGHT FROM THE EDGE OF SHOULDER |



MILEPOST MARKER

STANDARD F11-06

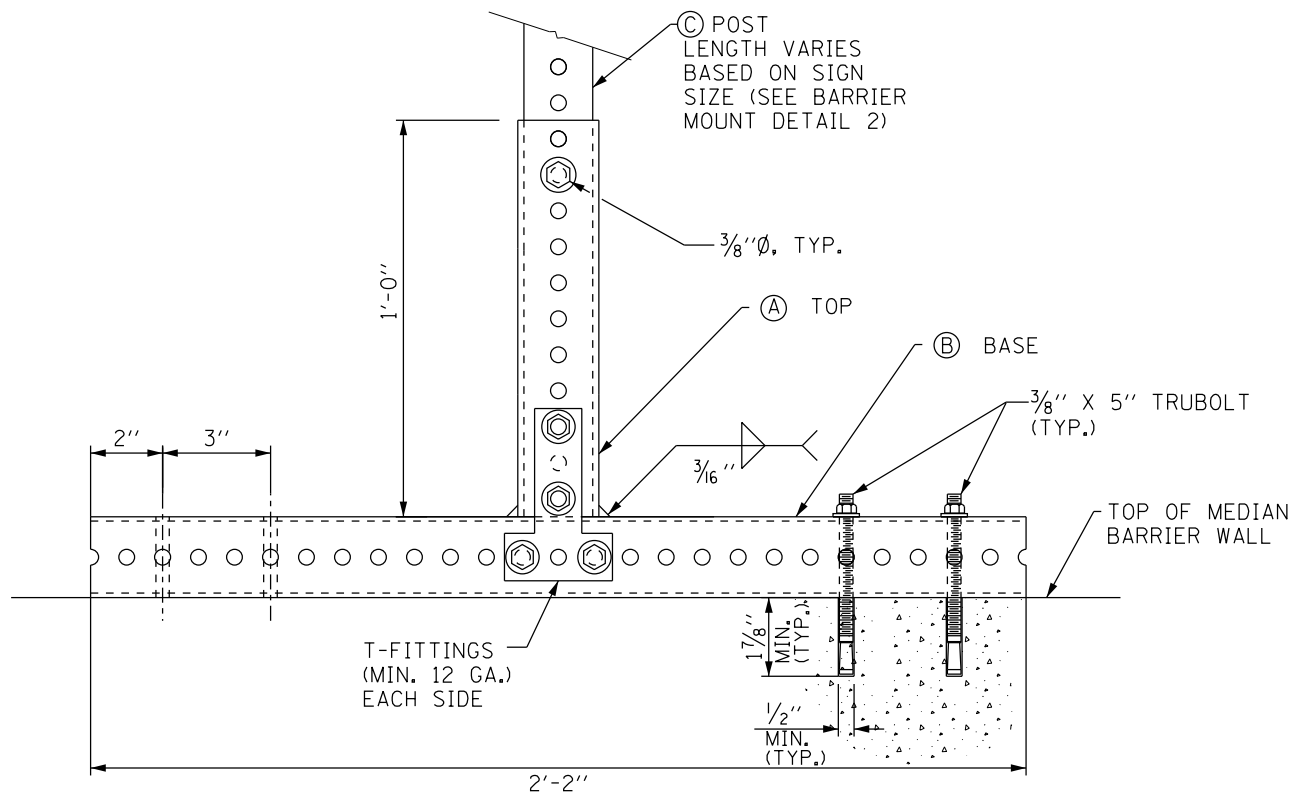

BARRIER MOUNT DETAIL

NOT TO SCALE

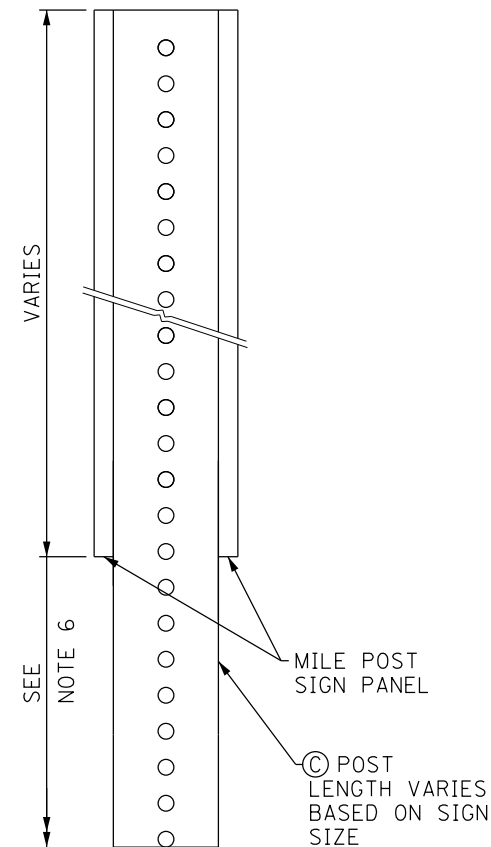

BARRIER MOUNT DETAIL 2

NOT TO SCALE

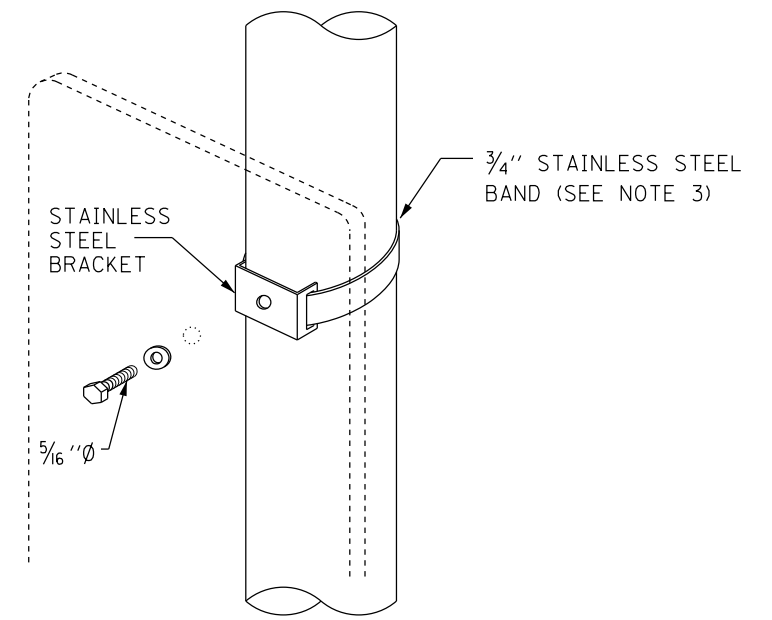

LIGHT POLE/SIGN STRUCTURE MOUNT DETAIL

NOT TO SCALE

GENERAL NOTES:

1. ALL ANCHOR BOLTS FOR MEDIAN BARRIER MOUNT DETAIL SHALL BE 3/8" DIA. RED HEAD "TRUBOLT" OR APPROVED EQUAL.
2. ALL DIMENSIONS ARE IN INCHES UNLESS SHOWN OTHERWISE.
3. FOLLOWING ARE THE STEPS FOR FASTENING THE MILEPOST MARKER SIGN PANEL. ALL MOUNTING DETAILS SHOWN ON THIS SHEET APPLY:
 - a. CENTER ALL FASTENERS ON THE SIGN PANEL.
 - b. START AND FINISH THE FASTENER SPACING USING A MINIMUM OF 3" TO A MAXIMUM OF 6" FROM THE TOP AND BOTTOM EDGE OF THE SIGN PANEL.
 - c. THE DISTANCE BETWEEN SUCCESSIVE FASTENERS SHALL NOT EXCEED 2'-0".
4. CENTER THE 5/16" DIA. BOLT IN THE MIDDLE OF THE SIGN.
5. USE THE SAME ATTACHMENT FOR BACK TO BACK MILEPOST MARKER SIGN.
6. DISTANCE FROM THE EDGE OF SHOULDER TO THE BOTTOM OF THE MILEPOST MARKER SIGN SHALL BE A MINIMUM OF 4'-0" REGARDLESS OF BARRIER TYPE.
7. THE TOP SECTION SHALL BE TELESKOPEDED INTO THE BASE SECTION 12 INCHES AND FASTENED TOGETHER.
8. FOR ATTACHMENT TO BRIDGE PARAPET USE BARRIER WALL MOUNT DETAIL. ONLY ONE PANEL REQUIRED WHEN ATTACHED TO PARAPET ALONG OUTSIDE SHOULDER.
9. BASE AND POST ASSEMBLY SHALL BE HOT DIP GALVANIZED AFTER FABRICATION IN ACCORDANCE WITH AASTHO M111 OR AS SPECIFIED IN THE SPECIAL PROVISION.

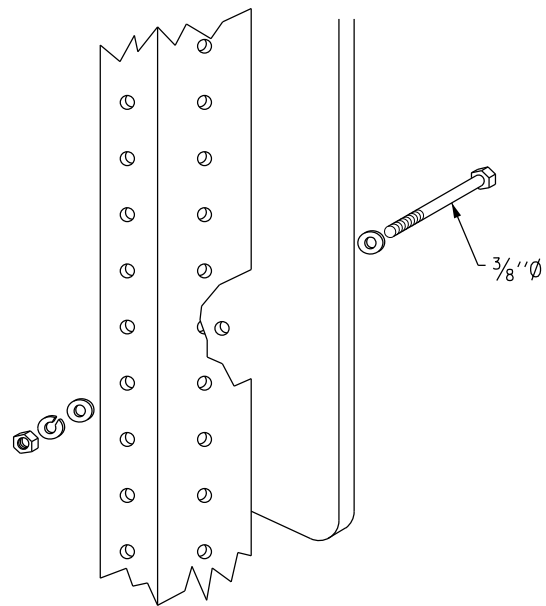

TELESKOPEDED STEEL POSTS

NOT TO SCALE

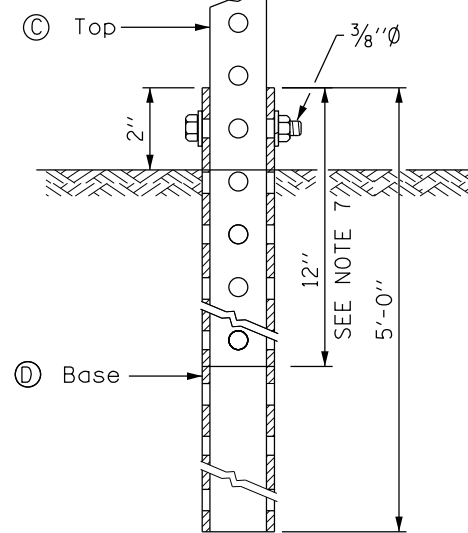

GROUND MOUNT DETAIL

NOT TO SCALE

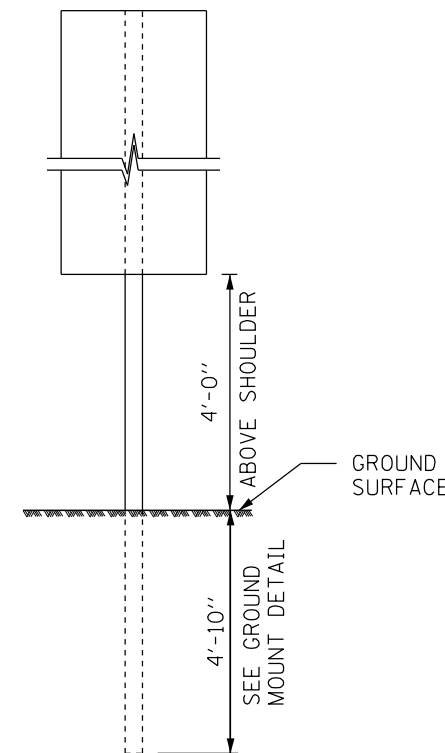

ONE POST INSTALLATION

NOT TO SCALE

| | |
|-----|----------------------------------|
| (A) | 2 1/4" x 2 1/4" x 1'-0" (12 GA.) |
| (B) | 2 1/4" x 2 1/4" x 2'-2" (12 GA.) |
| (C) | 2" x 2" x VARIES (12 GA.) |
| (D) | 2 1/4" x 2 1/4" x 5'-0" (12 GA.) |



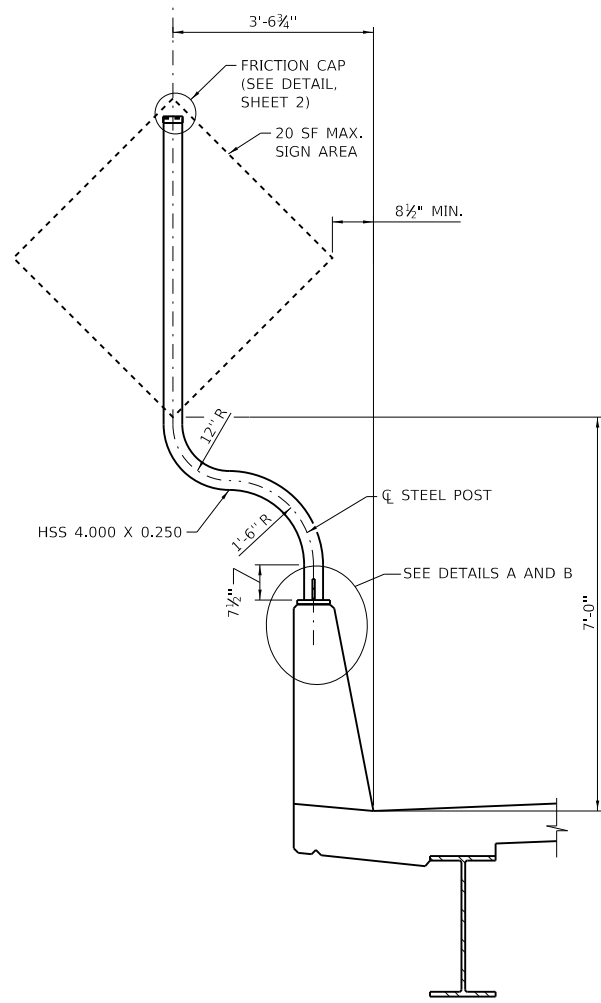

PARAPET MOUNTED SIGN
(MAXIMUM SIGN AREA 20 SF)

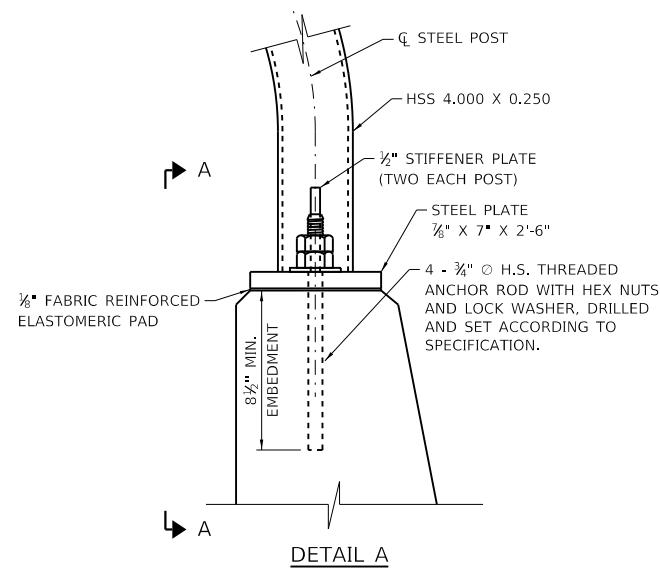

DETAIL A

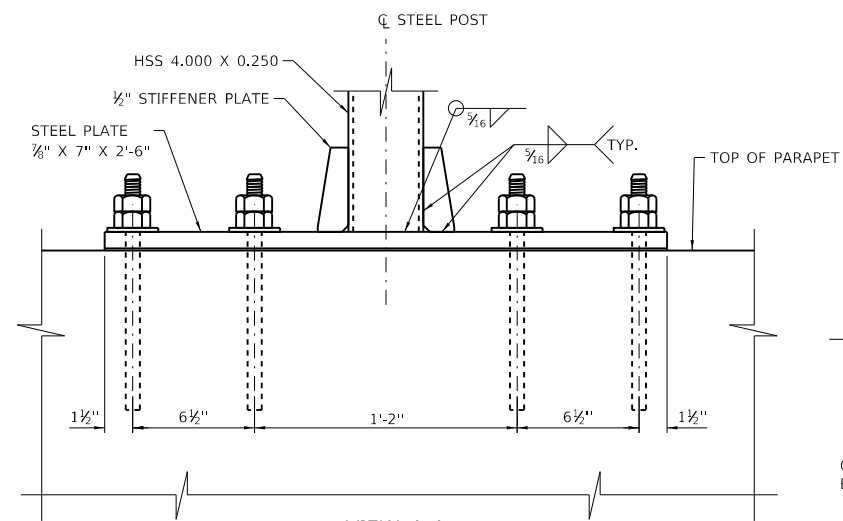

VIEW A-A

POST INSTALLED DETAIL
(MAXIMUM SIGN AREA 20 SF)

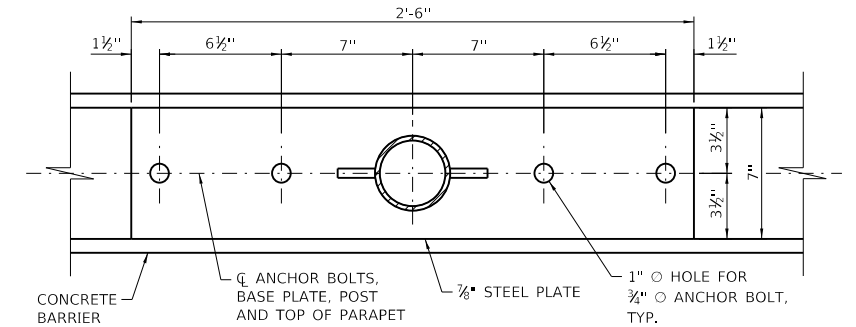

BASE PLATE DETAIL
(FOR POST INSTALLED CONDITION)

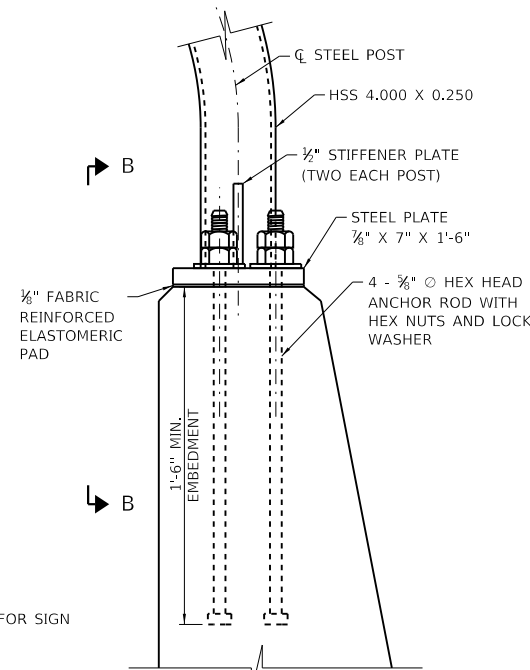

DETAIL B

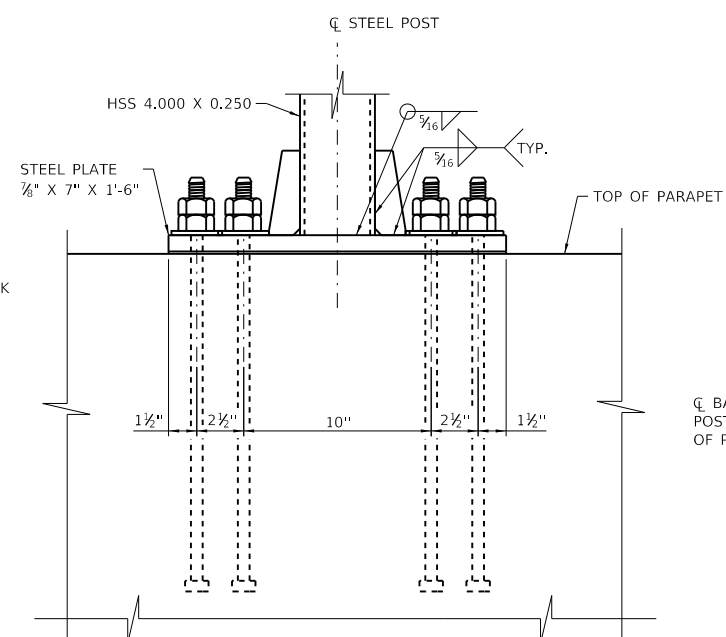

VIEW B-B

CAST-IN-PLACE DETAIL
(MAXIMUM SIGN AREA 20 SF)

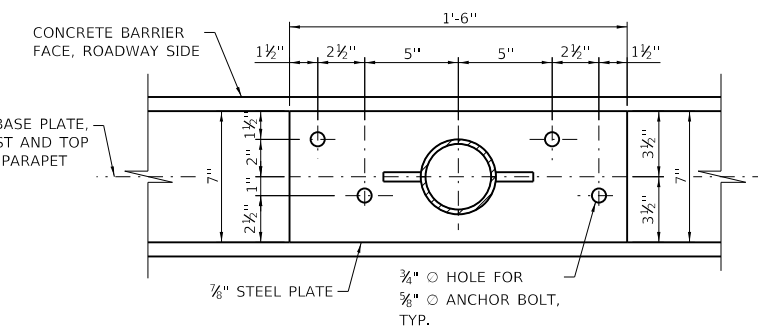

BASE PLATE DETAIL
(CAST-IN-PLACE INSTALLATION)

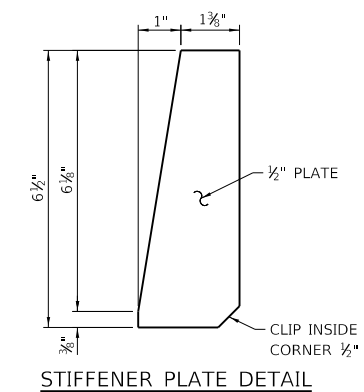

STIFFENER PLATE DETAIL

NOTES:

- FOR MATERIAL, FABRICATION, ERECTION, AND OTHER REQUIREMENTS, REFER TO ILLINOIS TOLLWAY "STRUCTURAL SUPPORT FOR SIGN PANELS" SPECIAL PROVISION.
- THESE DETAILS ARE NOT INTENDED FOR PORTABLE AND/OR PRECAST BARRIER.
- DESIGN CONFORMS TO THE 2015 EDITION OF THE AASHTO STANDARD SPECIFICATIONS FOR HIGHWAY SIGNS, LUMINAIRES, AND TRAFFIC SIGNALS WITH 2017 INTERIM SPECIFICATIONS THERETO. DESIGN WIND SPEEDS OF 3-S GUST WITH SPEED OF 120 MPH PLUS 14% GUST FACTOR, AND A WIND IMPORTANCE FACTOR OF 1.0 (50 YEAR MEAN RECURRENCE INTERVAL) FOR THE SUPPORTING STRUCTURES.
- THE PARAPET WALL SHALL BE DESIGNED TO SAFELY SUPPORT THE PROPOSED SIGN PANELS IN ACCORDANCE WITH NOTE 3.
- WELDED PLATES MAY BE USED IN LIEU OF THE BENT PLATE OF MOUNTING PLATE SHOWN. ALL STEEL ELEMENTS SHALL BE GALVANIZED AFTER FABRICATION.
- EXISTING REINFORCING BARS IN THE CONCRETE STRUCTURES MAY CONFLICT WITH SPECIFIC ANCHOR LOCATIONS. THE CONTRACTOR SHALL LOCATE THE POSITION OF THE REINFORCING BARS AT THE LOCATIONS OF THE CONCRETE ANCHORS. DRILLED HOLES FOR ANCHOR RODS SHALL BE CAREFULLY PLACED TO AVOID INTERFERENCE WITH EXISTING REINFORCEMENT.
- NO ANCHOR BOLT SHALL BE PLACED CLOSER THAN 12" FROM PARAPET WALL EXPANSION JOINT.
- TWO STIFFENER PLATES (ONE ON EACH SIDE OF POST) SHALL BE WELDED AS SHOWN ON PLANS IN DIRECTION PERPENDICULAR TO SIGN.
- INSTALLATION SHALL BE DONE IN ACCORDANCE WITH ILLINOIS TOLLWAY SPECIAL PROVISION "SIGN INSTALLATION".
- THIS STANDARD SHALL BE UTILIZED TO MOUNT SIGN SUPPORT ON SINGLE FACE PARAPETS CONSTRUCTED ON BRIDGES, WALLS AND MOMENT SLABS.

MATERIAL SPECIFICATIONS FOR STRUCTURAL STEEL AND FASTENERS

| ELEMENTS OF STRUCTURE | MINIMUM YIELD STRENGTH (K.S.I.) | MINIMUM ULTIMATE STRENGTH (K.S.I.) |
|-----------------------|---------------------------------|------------------------------------|
| STRUCTURAL STEEL TUBE | 42 | 58 |
| STEEL ANCHOR BOLTS | 36 | 58 |

APPROVED *Paul Kovacs* DATE 2-24-2020
CHIEF ENGINEERING OFFICER

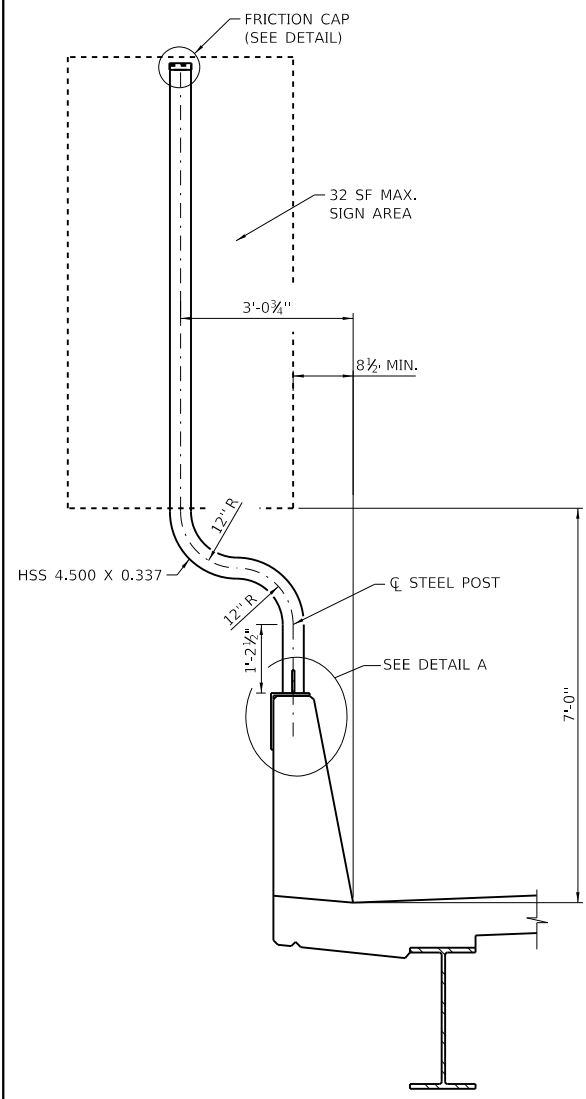

PARAPET MOUNTED SIGN
(MAXIMUM SIGN AREA 32 SF)

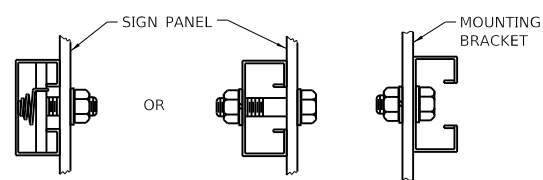

DETAIL B

DETAIL C

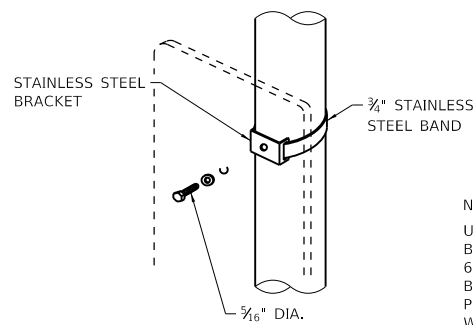

SIGN PANEL 36" WIDE OR LESS

NOTE:
USE A MINIMUM OF 2 BRACKETS (LOCATED 6" FROM TOP AND BOTTOM OF SIGN) PER INSTALLATION WITH MAXIMUM SPACING OF 3'-0".

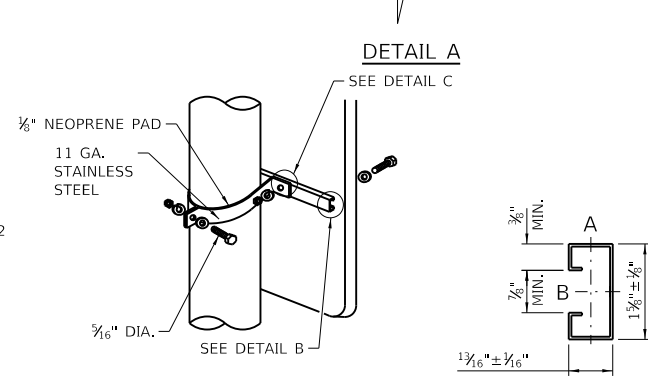

SIGN PANEL OVER 36" WIDE

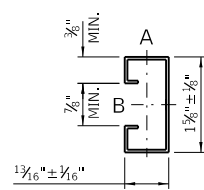

SUPPORTING CHANNEL DETAILS

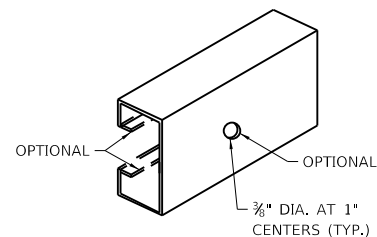

OPTIONAL

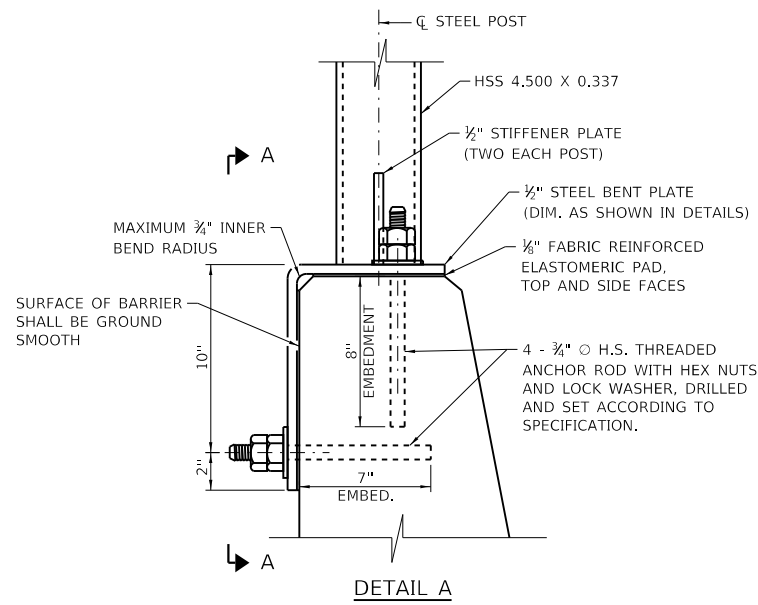

DETAIL A

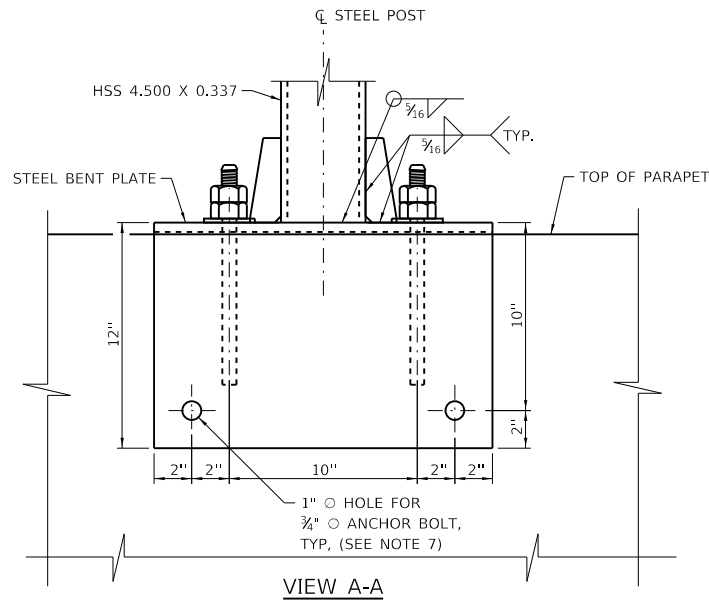

VIEW A-A

POST INSTALLED DETAIL
(MAXIMUM SIGN AREA 32 SF)

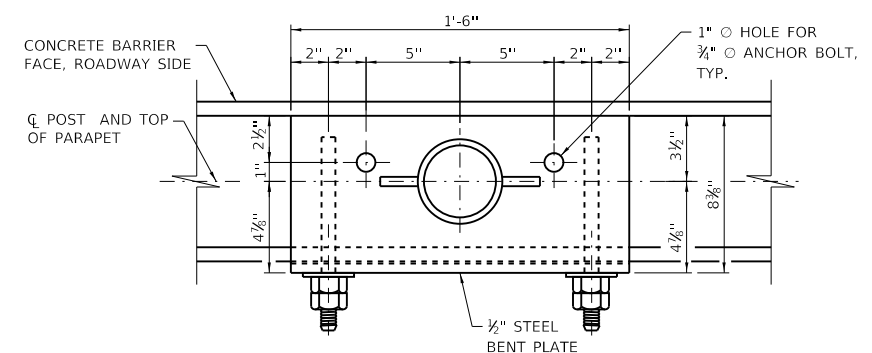

BASE PLATE DETAIL
(FOR POST INSTALLED CONDITION)

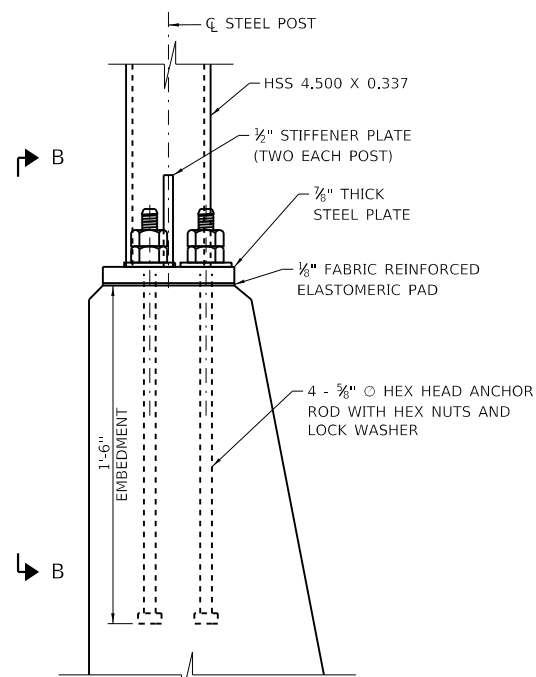

DETAIL A

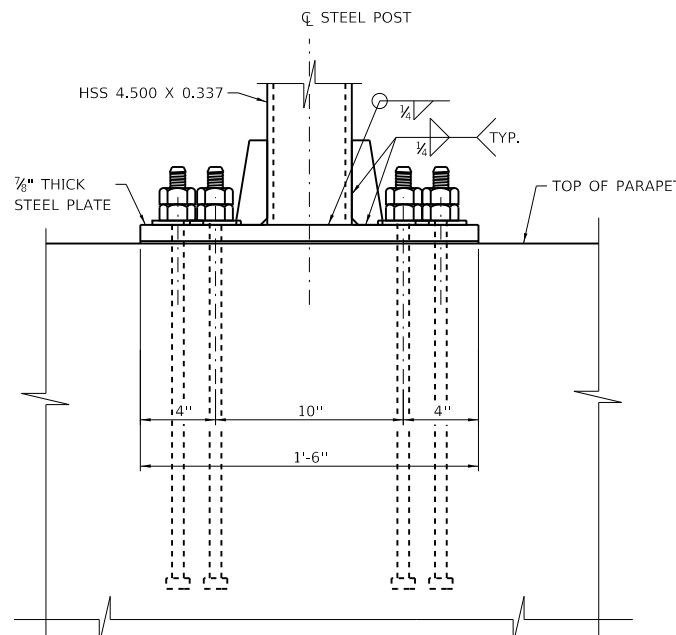

VIEW B-B

CAST-IN-PLACE DETAIL
(MAXIMUM SIGN AREA 32 SF)

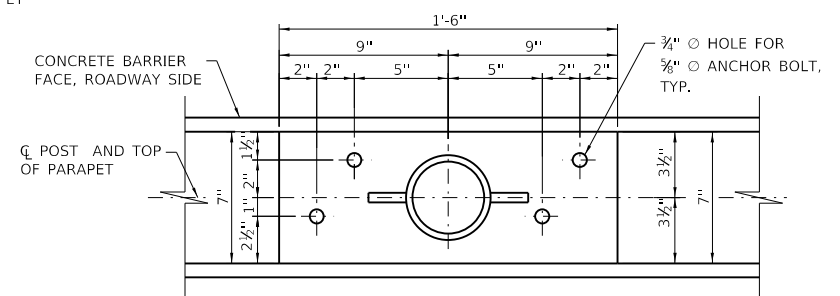

BASE PLATE DETAIL
(CAST-IN-PLACE INSTALLATION)

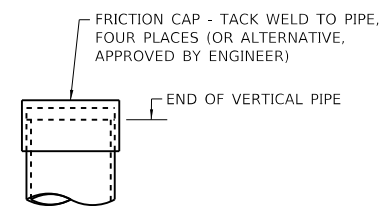

FRICION CAP DETAIL



| SUPPORTING CHANNEL SECTION MODULUS (MINIMUM) | Axis A | Axis B |
|--|-----------------------|-----------------------|
| STEEL | 0.050 in ³ | 0.105 in ³ |
| ALUMINUM | 0.150 in ³ | 0.315 in ³ |

APPROVED: *Paul Kovacs* DATE: 2-24-2020
CHIEF ENGINEERING OFFICER

MOUNTING BRACKET DETAILS

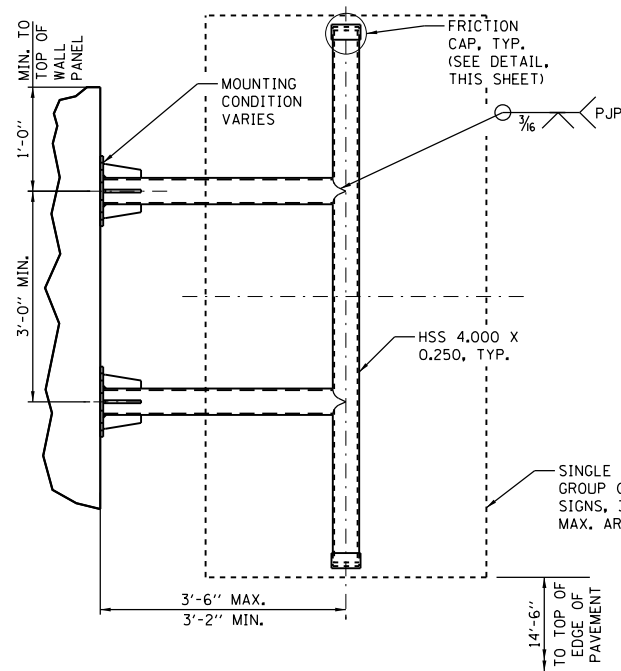

SIGN PANEL MOUNT
(MAXIMUM SIGN AREA 32 SF)

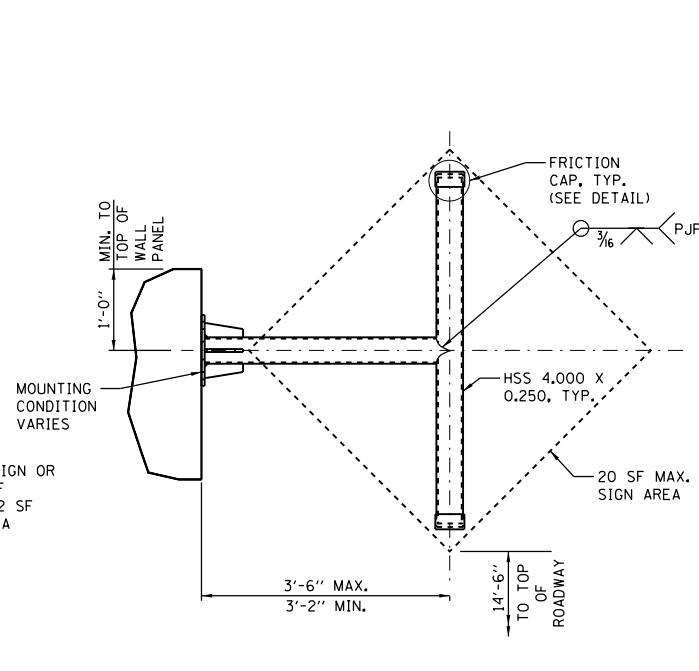

SIGN PANEL MOUNT
(MAXIMUM SIGN AREA 20 SF)

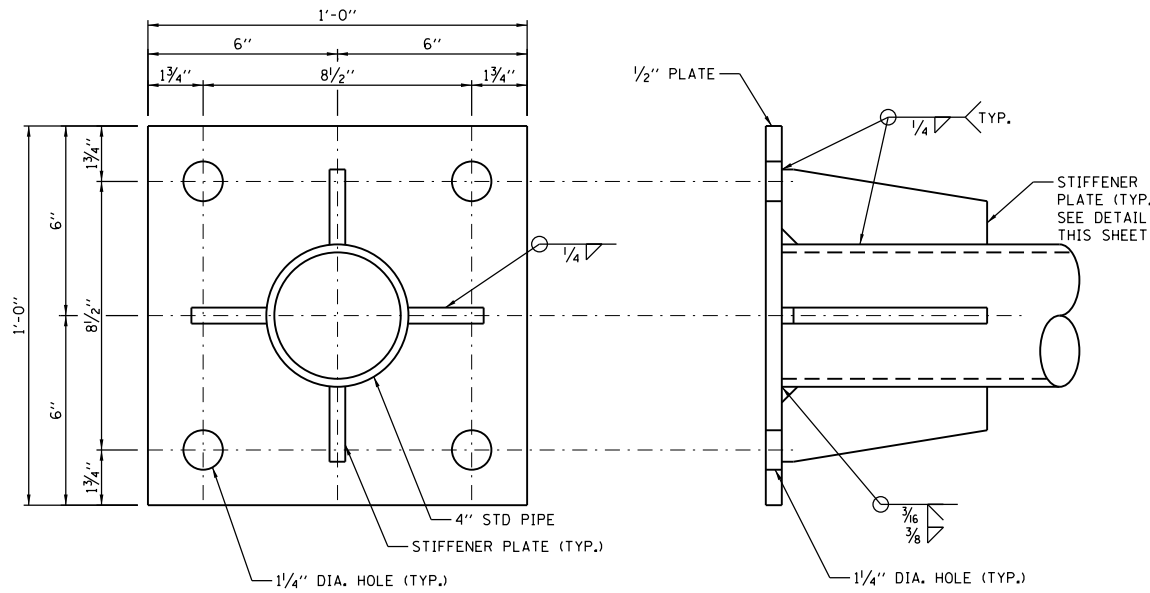

BASE PLATE DETAILS

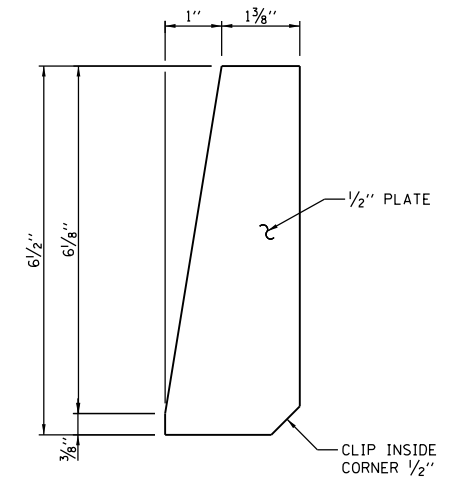

STIFFENER PLATE DETAIL

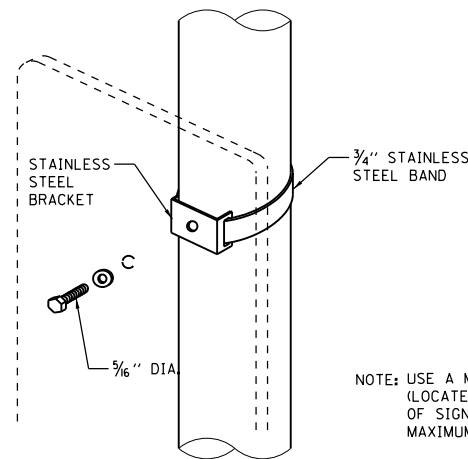

MOUNTING BRACKET DETAIL

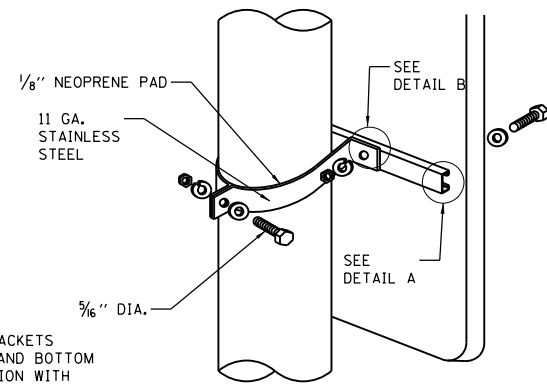

MOUNTING BRACKET DETAIL

| SUPPORTING CHANNEL SECTION MODULUS (MINIMUM) | Axis A | Axis B |
|--|-----------------------|-----------------------|
| STEEL | 0.050 in ³ | 0.105 in ³ |
| ALUMINUM | 0.150 in ³ | 0.315 in ³ |

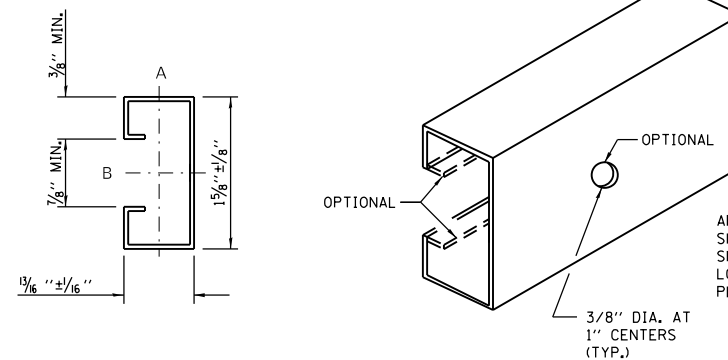

SUPPORTING CHANNEL DETAILS

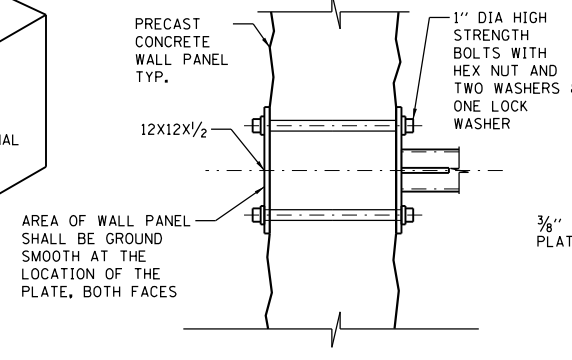

CONNECTION TO PANEL

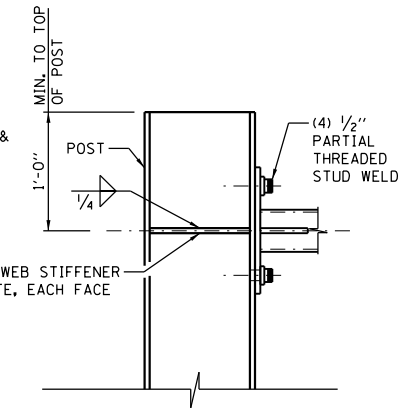

CONNECTION TO POST

NOTES:

- FOR MATERIAL, FABRICATION, ERECTION, AND OTHER REQUIREMENTS, REFER TO ILLINOIS TOLLWAY "STRUCTURAL SUPPORT FOR SIGN PANELS" SPECIAL PROVISION.
- DESIGN CONFORMS TO THE 2015 EDITION OF THE AASHTO STANDARD SPECIFICATIONS FOR HIGHWAY SIGNS, LUMINAIRES, AND TRAFFIC SIGNALS WITH 2017 INTERIM SPECIFICATIONS THERETO. DESIGN WIND SPEEDS OF 3-5 GUST WITH SPEED OF 120 MPH PLUS 14% GUST FACTOR, AND A WIND IMPORTANCE FACTOR OF 1.0 (50 YEAR MEAN RECURRENCE INTERVAL) FOR THE SUPPORTING STRUCTURES.
- ALL FABRICATION SHALL BE COMPLETE AND READY FOR ASSEMBLY BEFORE GALVANIZING. NO PUNCHING, DRILLING, CUTTING, NOR WELDING SHALL BE PERMITTED AFTER GALVANIZING.
- THE WALL PANELS AND/OR POSTS SHALL BE DESIGNED TO SAFELY SUPPORT THE PROPOSED SIGN PANELS IN ACCORDANCE WITH NOTE 2.
- FOR SIGN CONNECTION TO MOUNTING BRACKET, SHOP DRILL HOLES ON SIGN IN ACCORDANCE WITH THE CURRENT STANDARD HIGHWAY SIGN DESIGNS FOR ILLINOIS. ADDITIONAL HOLES NEEDED TO MEET A STIPULATED TYPE MOUNTING MAY BE FIELD DRILLED.
- ALL THREADED RODS SHALL CONFIRM TO ASTM F1554 GRADE 105, EACH WITH ONE PLATE WASHER AND LOCKNUT AND BE HOT DIP GALVANIZED PER ASTM A153 (AASHTO M232). THEY SHALL BE INSTALLED IN ACCORDANCE WITH SECTION 1211 OF ILLINOIS TOLLWAY SUPPLEMENTAL SPECIFICATIONS TO THE IDOT STANDARD SPECIFICATIONS.
- A NYLON WASHER SHALL BE PLACED BETWEEN THE SIGN FACE AND ANY OTHER WASHER REQUIRED ON SIGNS CONSTRUCTED OF ASTM TYPE III OR IV SHEETING.
- CONTRACTOR SHALL VERIFY APPLICABLE FIELD DIMENSIONS BEFORE FABRICATION. HOLES DRILLED THROUGH NOISE ABATEMENT WALL SHALL BE DRILLED WITH ROTARY (CORING OR MASONRY DRILL) TYPE EQUIPMENT. PERCUSSION (STAR) DRILLING SHALL NOT BE ALLOWED.
- CENTER LINE OF BOLTS INTO NOISE ABATEMENT WALL SHALL BE AT LEAST 12" TO CENTER LINE OF OPEN JOINT IN WALL.

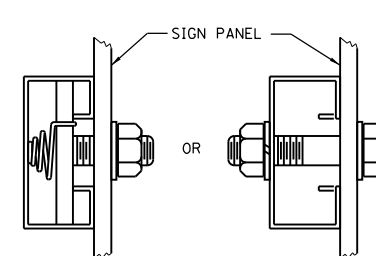

DETAIL A

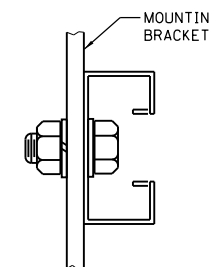

DETAIL B

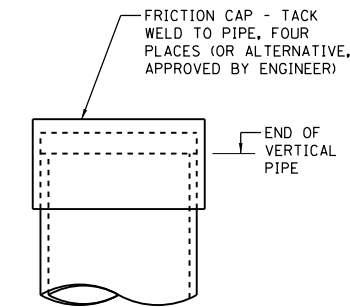

FRICTION CAP DETAIL

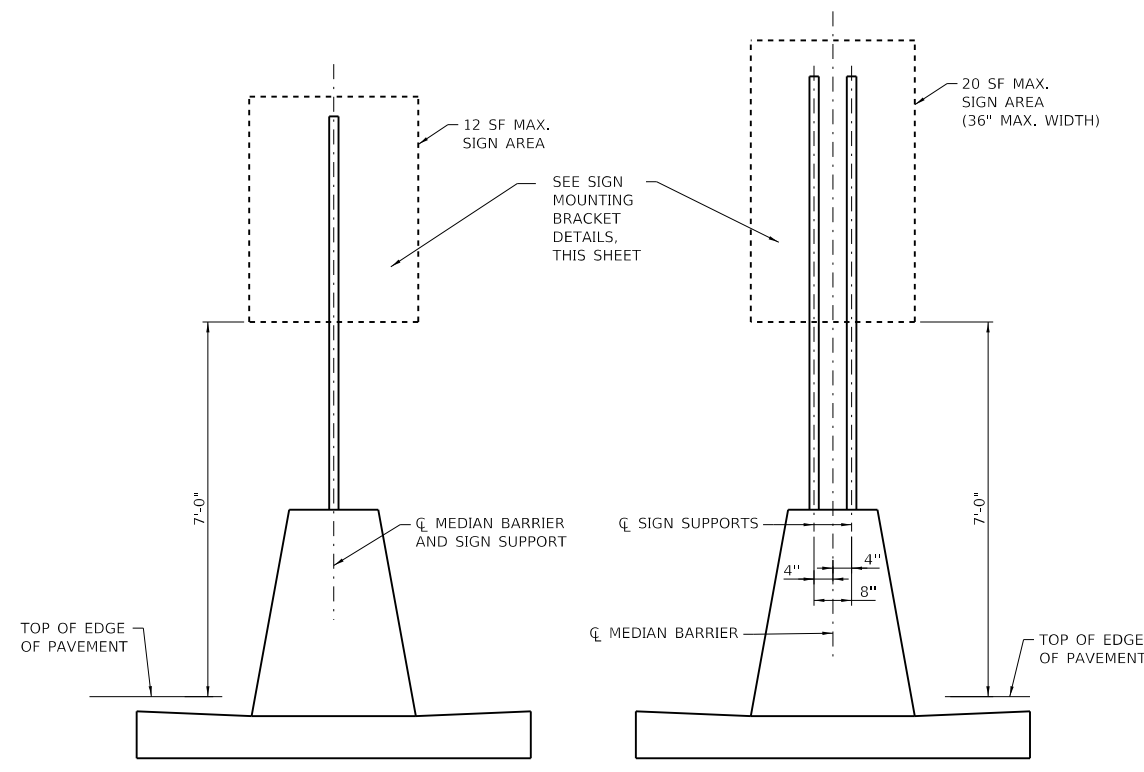

ONE POST INSTALLATION

TWO POSTS INSTALLATION

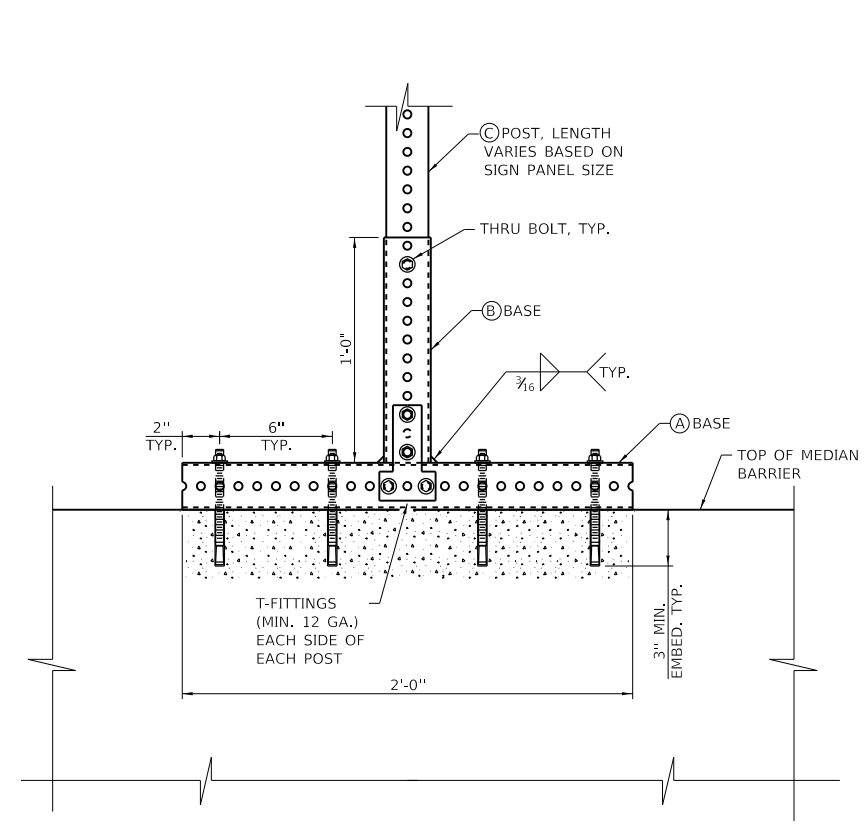

SIDE ELEVATION - BARRIER MOUNT DETAIL

(LOOKING PERP. TO TRAFFIC)

NOTES:

1. ALL ANCHOR BOLTS FOR MEDIAN BARRIER MOUNTED SIGN SUPPORT ASSEMBLY SHALL BE $\frac{3}{8}$ " DIA. EXPANSION ANCHORS.
2. THE TOP SECTION SHALL BE TELESOPED INTO THE BASE SECTION 12 INCHES AND FASTENED TOGETHER.
3. DESIGN CONFORMS TO THE 2015 EDITION OF THE AASHTO STANDARD SPECIFICATIONS FOR HIGHWAY SIGNS, LUMINAIRES, AND TRAFFIC SIGNALS WITH 2017 INTERIM SPECIFICATIONS THERETO. DESIGN WIND SPEEDS OF 3-5 GUST WITH SPEED OF 120 MPH PLUS 14% GUST FACTOR, AND A WIND IMPORTANCE FACTOR OF 1.0 (50 YEAR MEAN RECURRENCE INTERVAL) FOR THE SUPPORTING STRUCTURES.
4. NO ANCHOR BOLT SHALL BE PLACED CLOSER THAN 12" FROM CENTER LINE OF MEDIAN BARRIER JOINT.
5. SIGN FABRICATION AND INSTALLATION SHALL BE DONE IN ACCORDANCE WITH ILLINOIS TOLLWAY SPECIAL PROVISION "SIGN INSTALLATION".
6. BASE AND POST ASSEMBLY SHALL BE HOT DIP GALVANIZED AFTER FABRICATION IN ACCORDANCE WITH AASTHO M111 OR AS SPECIFIED IN THE SPECIAL PROVISION "TELESCOPING STEEL SIGN SUPPORT, BARRIER ASSEMBLY".
7. ALL MATERIALS FOR THE SIGN SUPPORT ASSEMBLY SHALL BE INCLUDED IN THE COST OF "TELESCOPING STEEL SIGN SUPPORT, BARRIER ASSEMBLY".

MEMBER DETAILS

| | |
|-----|-----------------------------|
| (A) | 2½" x 2½" x 1'-0" (12 GA.) |
| (B) | 2½" x 2½" x 1'-0" (12 GA.) |
| (C) | 2½" x 2½" x VARIES (12 GA.) |

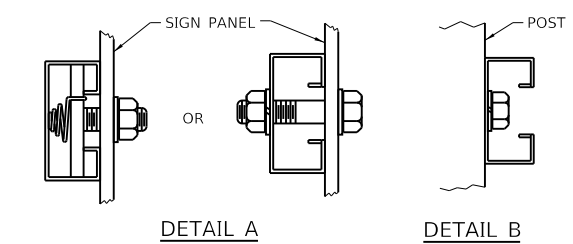

DETAIL A

DETAIL B

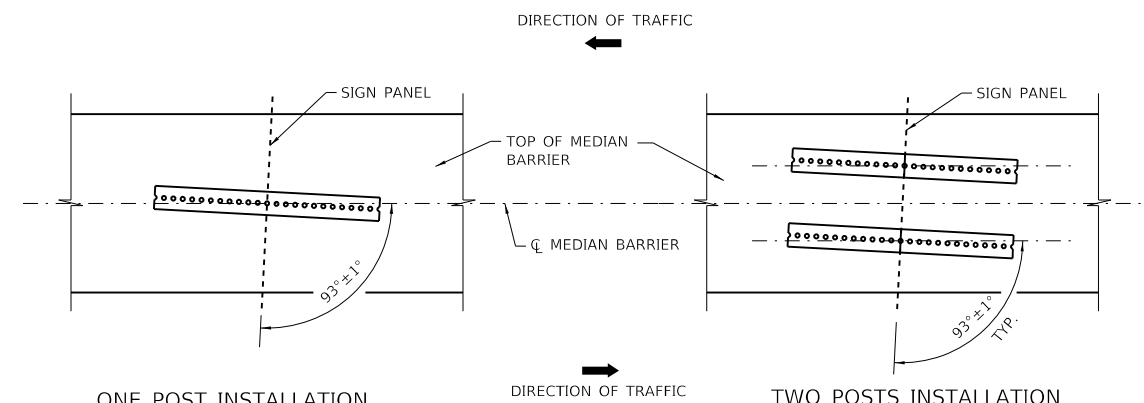

ONE POST INSTALLATION

TWO POSTS INSTALLATION

PLAN VIEW

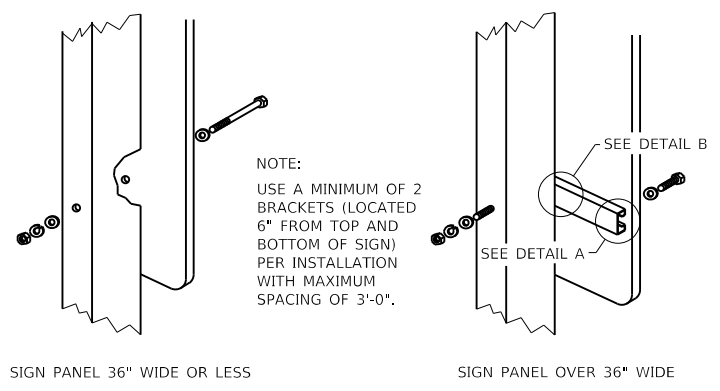

MOUNTING BRACKET DETAILS

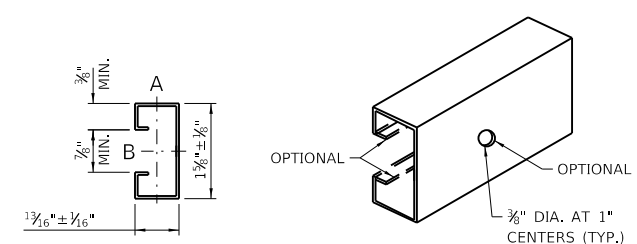

SUPPORTING CHANNEL DETAILS

| SUPPORTING CHANNEL SECTION MODULUS (MINIMUM) | Axis A | Axis B |
|--|------------------------|------------------------|
| STEEL | 0.050 in. ³ | 0.105 in. ³ |
| ALUMINUM | 0.150 in. ³ | 0.315 in. ³ |

APPROVED: *Paul Kovacs* DATE 2-24-2020
CHIEF ENGINEERING OFFICER



MEDIAN BARRIER MOUNTED SIGN SUPPORT

STANDARD F20-01

STRUCTURAL SUPPORT FOR SIGN PANELS (Illinois Tollway)

Effective: February 13, 2020

Description: This work shall consist of furnishing and installing structural sign supports for parapet mounted and noise abatement wall mounted signs.

Materials: Materials used in the fabrication of the sign supports shall be to the requirements shown in the Plans and to the following:

- a. Structural Steel Round Tube: All structural steel tube shall conform to ASTM A500, Grade B. The tubing shall be galvanized inside and outside.
- b. Steel Plates: Steel plates shall conform to the requirements of the ASTM A36 (AASHTO M183) or ASTM A572 Grade 50, as specified in the plans.
- c. High-Strength Anchor Bolts shall conform to ASTM F1554 (AASHTO M314) Grade 36 if not specified in the plan.
- d. Miscellaneous fasteners and hardware shall conform to Article 1006.08 of Standard Specification.

Construction Requirements

Setting Anchor Rods. Drilled holes in concrete for anchor rods shall be to the diameter and depth required by the adhesive manufacturer for the size and type of anchor rod specified in the plans. The requirements of Article 509.06 of the Standard Specifications shall apply.

Shop Drawings shall be prepared and submitted for approval in accordance with Article 505.03 of the Standard Specifications after the Contractor has documented the location and orientation of the anchor bolts at all proposed supports.

Fabrication. The requirements of Article 505.04 of the Standard Specifications shall apply, except as modified below.

- (a) The steel post and base plates shall be fabricated in accordance with the plans.
- (b) Welding
 - (1) Welding shall conform to Article 505.04(q) of the Standard Specifications.
 - (2) All welding shall be done to minimize distortion. Permissible Structural Steel Tube (HSS) dimension variations for outside dimensions, wall thickness, length, straightness, squareness of sides and twist shall be in accordance with Section 8 of ASTM A618 for frame members and Section 11 of ASTM A500 for mounting beams.
- (c) Galvanizing
 - (1) Hot dip galvanized structural steel tubing, splice plates, base plates, misc. structural steel and plates in accordance with AASHTO M 111 and ASTM

A385. Galvanize shall be performed after welding, fabrication and drilling all holes.

- (2) All bolts, nuts, lock nuts and washers shall be galvanized in accordance with the hot-dipped process conforming to AASHTO M 232, Class C.
- (3) Zinc-coated nuts shall be tapped oversize according to the requirements of AASHTO M 291 and shall meet the supplementary requirements of S1.1 through S1.2.1 of the same specifications for lubricant and testing. The lubricant shall be tinted to produce a distinct contrast with the nut.
- (4) Do not galvanize stainless steel parts.

Erection. Erection of structural steel for the sign support shall conform to the applicable provisions of Articles 733.05(a) and 733.05(b) of the Illinois Tollway Supplemental Specifications.

Method of Measurement. This work will be measured for payment in units of each for all supports erected and accepted.

Basis of Payment. This work will be paid for at the contract unit price per each, for STRUCTURAL STEEL SIGN SUPPORT, of the type specified.

Sign installation will be paid for per square foot for SIGN INSTALLATION, of the type specified.

| Pay Item Number | Designation | Unit of Measure |
|-----------------|---|-----------------|
| JT728010 | STRUCTURAL STEEL SIGN SUPPORT, PARAPET MOUNTED | EACH |
| JT728020 | STRUCTURAL STEEL SIGN SUPPORT, NOISE WALL MOUNTED | EACH |

TELESCOPING STEEL SIGN SUPPORT, BARRIER ASSEMBLY (Illinois Tollway)

Effective: February 13, 2020

Description. This work shall consist of furnishing and installing sign supports for median barrier mounted signs at the location specified in the plans.

Materials. Materials shall be according to the following provisions of the Standard Specifications:

| | <u>Item</u> | <u>Article</u> |
|-----|---|----------------|
| (a) | Structural Steel Support, Telescoping (Note 1)..... | 1093.01(c) |
| (b) | Hardware (Note 2) | 1006.29(d) |

Note 1. This material specification is applicable to the base and post assembly. The maximum allowable twist in a 3 ft length and the permissible variation in squareness for the 2 ½” x 2 ½” square tube shall be 0.075 in and ±0.015 in respectively.

Note 2. The anchor bolts, nuts and washers shall be stainless steel.

Construction Methods. The assembly shall be installed using all required mounting hardware.

Method of Measurement. This work will be measured for payment in units of each for all supports erected and accepted.

Basis of Payment. This work will be paid for at the Contract unit price per each for TELESCOPING STEEL SIGN SUPPORT, BARRIER ASSEMBLY.

Sign installation will be paid for per square foot for SIGN INSTALLATION, of the type specified.

| Pay Item Number | Designation | Unit of Measure |
|--------------------|---|--------------------|
| JI728010 | TELESCOPING STEEL SIGN SUPPORT, BARRIER ASSEMBLY | EACH |
